

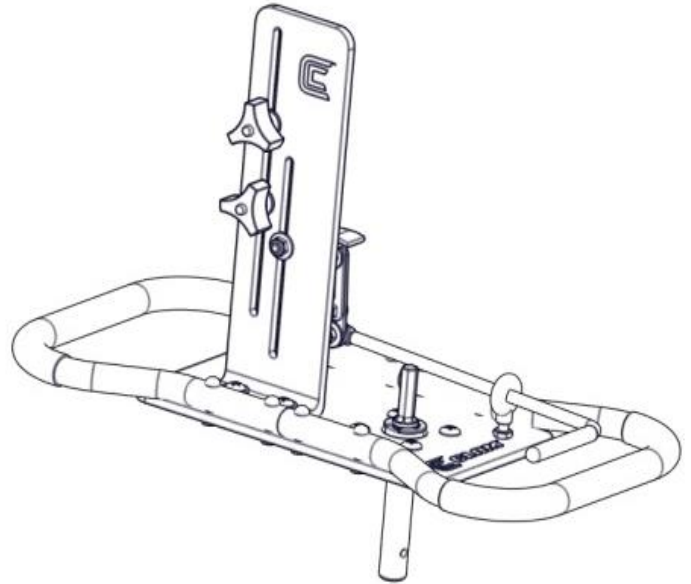

## AUGER DRILL PLATE KIT

Product Item Number-109935  
Instructions No.-104689



**NOTICE: Please contact Clam Customer Service directly for any quality issues with your Auger Drill Plate kit.**

- Customer Service Hrs: 9am to 4pm, Monday – Friday Central Standard Time
- Clam Corporation  
Attn: Customer Service – Warranty Department  
12135 Brockton Lane  
Rogers, MN 55369
- Phone: 763-231-4120
- Fax: 763-231-4121
- Email: [customerservice@clamcorp.com](mailto:customerservice@clamcorp.com)
- Website: [Clamoutdoors.com](http://Clamoutdoors.com)

**\*\* Clam Corporation cannot honor warranty without an original, dated receipt \*\***

### **Warranty Information:**

**Clam Corporation** warrants to the original retail purchaser (not transferable) its product to be free from manufacturers defects for one (1) year from the date of the original purchase. Clam Corporation will replace or repair (Clam's option) any part found defective within the one (1) year time frame. All parts must be returned to Clam Corporation. Before returning any parts, you must first contact Clam Corporation to obtain a **RMA (Return Material Authorization)**. All returns must be returned postage-prepaid and include the original cash register receipt (date and purchase price).

# PARTS LIST

PART NO.	QTY.	DESCRIPTION
104687	1	ASSY, AUGER PLATE
104681	1	BRACKET, DRILL AUGER
104679	1	ASSY, AUGER, THROTTLE TRIGGER
104688	1	ASSY, AUGER SHAFT
101082	3	NUT, 1/4-20 THIN NYLOCK YZ
103956	2	ASSEM, ADJUSTMENT KNOB
101081	8	WASHER, 1/4 FLAT REG YZ
103954	1	SCREW, 1/4-20 X 1.75 PH SB GR5
103955	1	U-BOLT, 1/4 X 20
101304	2	SCREW, 1/4-20 X 1" THPHCZ
104675	1	RETAINING RING 18MM SHAFT
104733	1	SPACER, BEARING , AUGER

**Note: Drill must be a 1/2" chuck drill and Clam recommends using at least an 18v DC drill for this setup.-Industrial is even better. Drill should be set to "low" speed too for more torque.**

## *Auger Drill Plate Assembly*

1. Install Bracket (104681) to main body using 2 screws(101304), 2 nuts(101082) and 4 washer(101081) Bracket must be positioned with Clam logo facing outward as shown. **(DO NOT TIGHTEN SECURELY)**

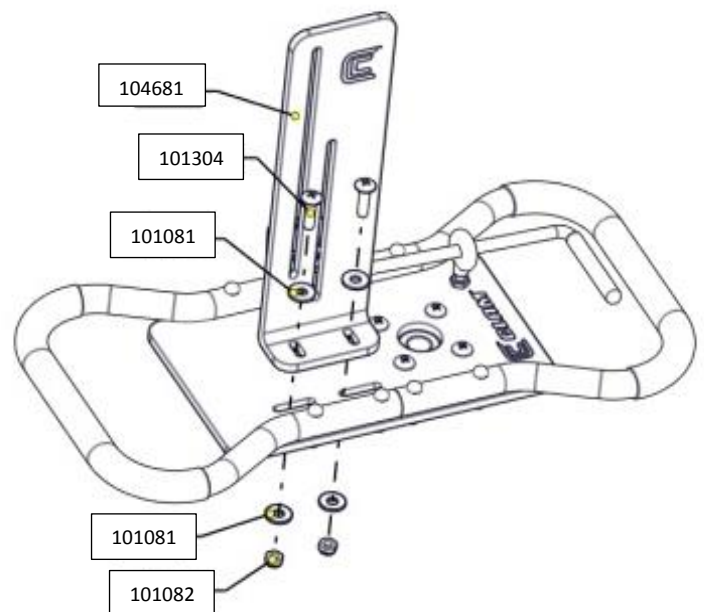

2. Install Throttle trigger assembly (104679) to Bracket (104681) using shoulder bolt (103954), 2 washers (101081) and nut (101082) as shown.

**(DO NOT TIGHTEN SECURELY)**

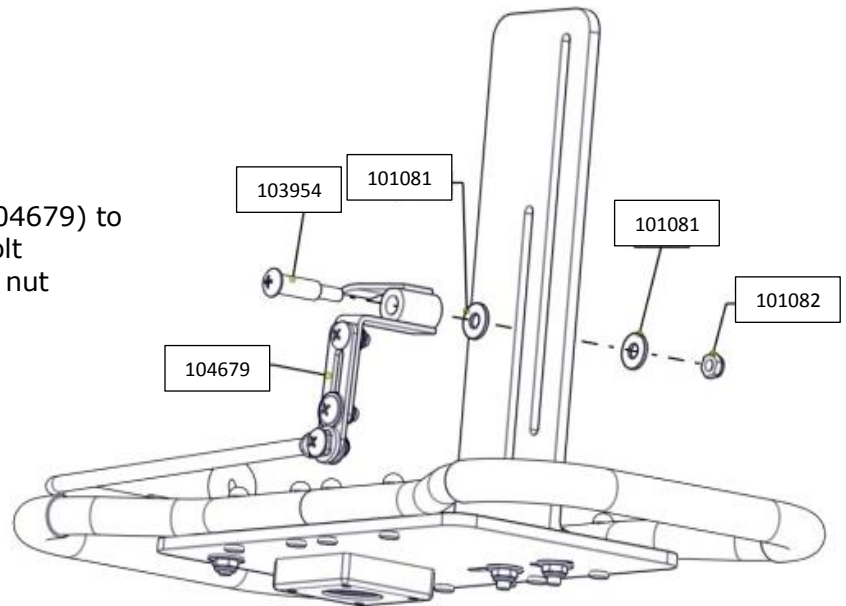

3. Slide Auger Shaft (104688) from underside of Auger thru bearing housing. From top side of auger slide Spacer (104733) over auger shaft (104688) and slide retaining ring (104675) into groove as shown.

**(DO NOT TIGHTEN SECURELY)**

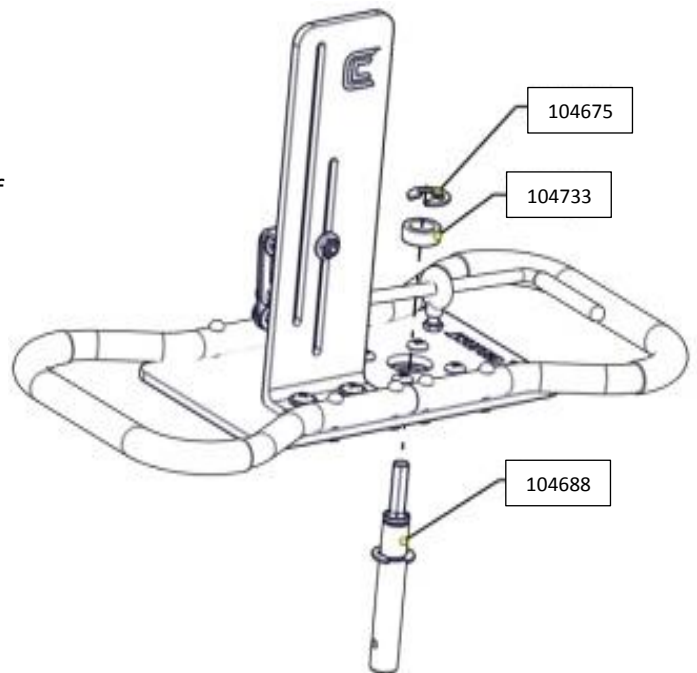

4. Place drill in position as shown and **tighten chuck securely** to auger shaft (104688). Slip U-bolt (103955) over drill handle and **securely tighten** to bracket (104681) using 2 washers (101081) and 2 knob handles (103956).

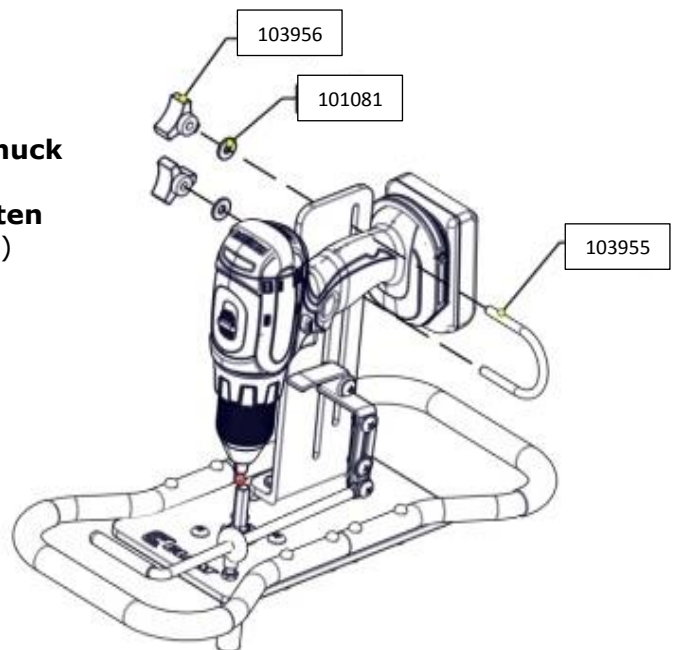

5. FINAL ADJUSTMENTS:

Adjust trigger paddle height so that the drill's trigger can be manipulated fully. You may need to adjust the side to side movement of the vertical bracket to achieve full depression of the trigger. Once trigger can be fully depressed by trigger linkage and paddle, tighten both the shoulder bolt going through the trigger paddle on linkage assembly to the vertical bracket, and the two bolts holding the vertical bracket in place to the drill plate.

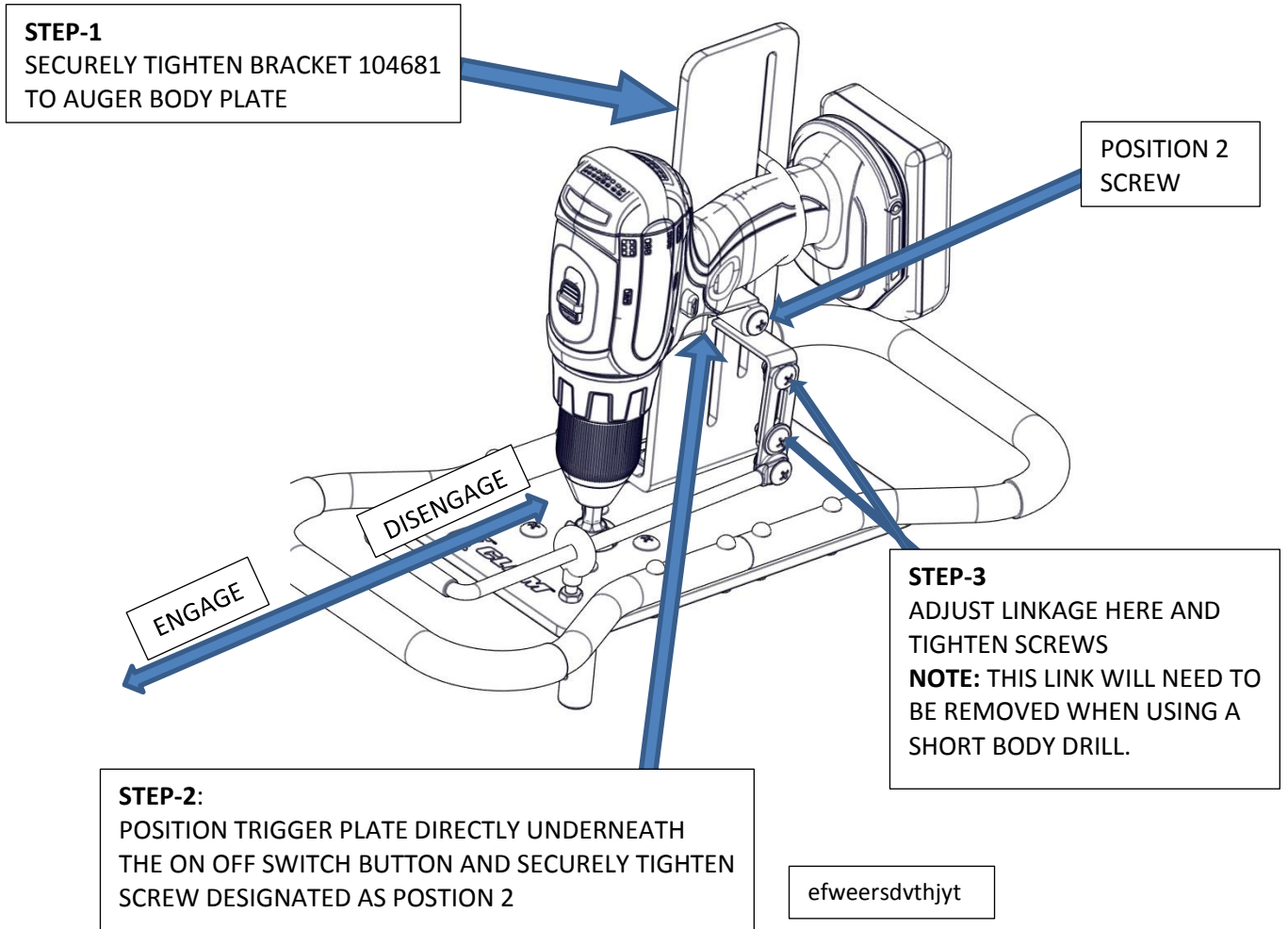

6. Assembly is now complete and the auger drill plate assembly is ready to accept whatever auger you'd like to mount on the motor shaft with the supplied M12 socket head bolt and 5mm allen wrench or wing bolt.

**NOTE:** caution should be used if wing bolt is installed as this part will rotate with shaft. Do not let it catch or snag on clothing.